

# STIL-FIT<sup>INT.</sup>

## Instruction Manual

## Rower FLOW ONE



Assembly tools:

You will need a size 13 open-end wrench and a size 5  
Allen key

**Delivery:**

You will receive 2 boxes with the following pre-assembled parts:

Front unit

Seat

Rear unit

Operating and assembly instructions

Charger

Pump

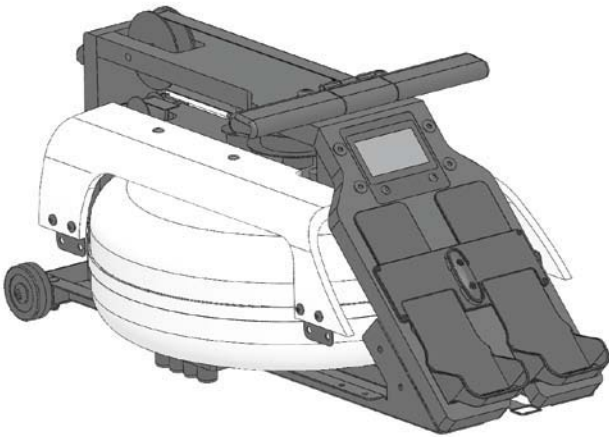

Front unit

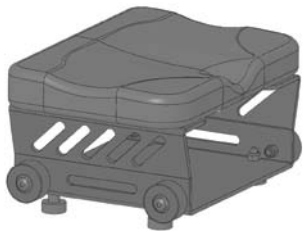

Seat



Rear unit  
Cover

## Assembly

### Step 1

Unscrew the wooden hull. You need an Allen key No. 5  
To do this, turn the unit inside the carton - frame downside

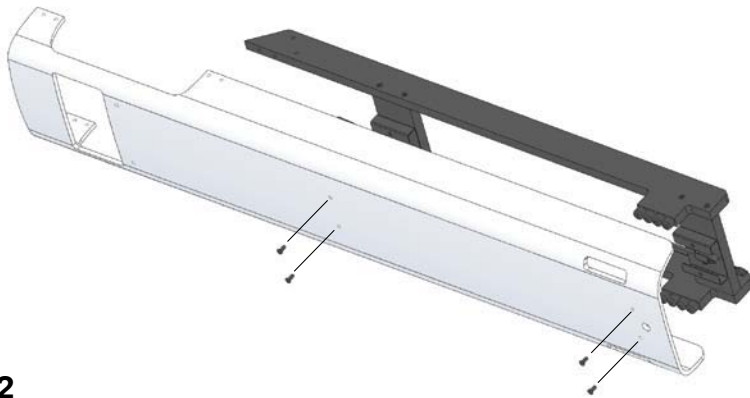

### Step 2

1. Place the front unit vertically on the floor.
2. Take the frame and screw it to the front unit. Start with the 4 screws and nuts (Pos. 2)
3. Then tighten the 4 screws (Pos. 1)

Tighten all screws securely.  
You will need an Allen key No. 5 and an open-ended wrench size 13.



M8 x 20

Countersunk head screw M8 x 45

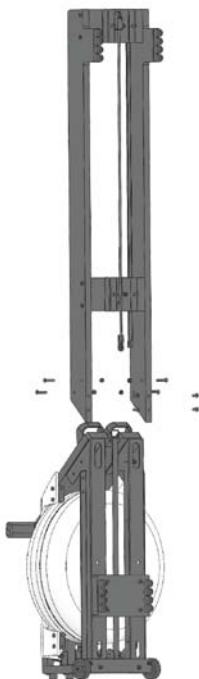

Countersunk head screw M8 x 45 (2)

Countersunk head screw M8 x 45 (2)

M8 x 20 (1)

M8 x 20 (1)

(1)

(1)

(2)

(2)

Countersunk head screw M8 x 45

(1) M8 x 20

(1) M8 x 20

(1)

(1)

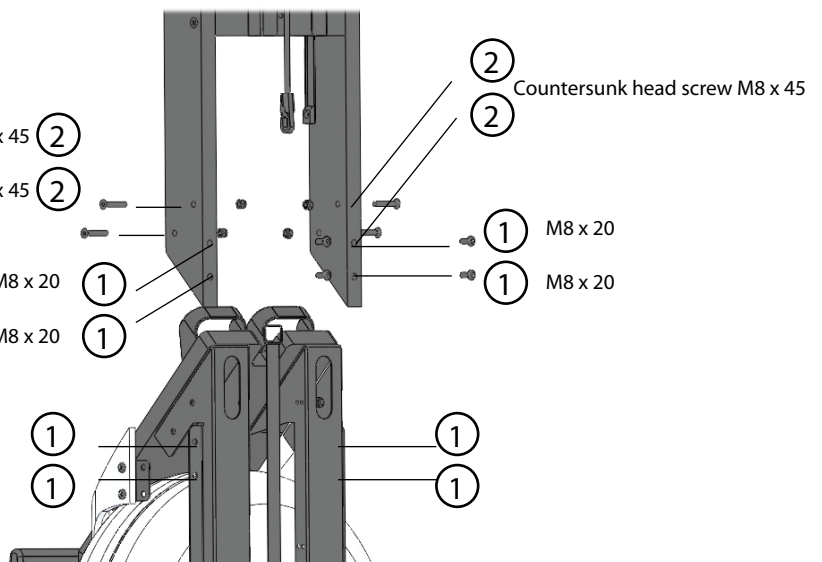

### Step 3

Now loosen the strap and attach the bungee cord to the strap.

The opening of the carabiner faces downwards.

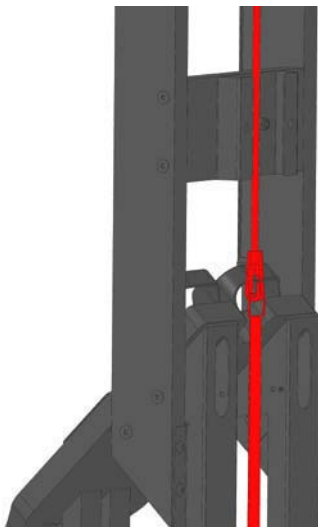

**Attention!**

Do not loosen the cable ties on the handle and the strap after you have attached the bungee!

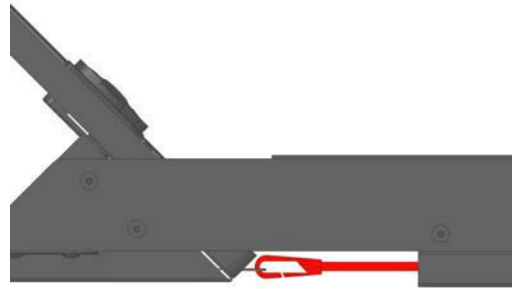

### Step 4

Take the wooden hull and put it on the wooden frame

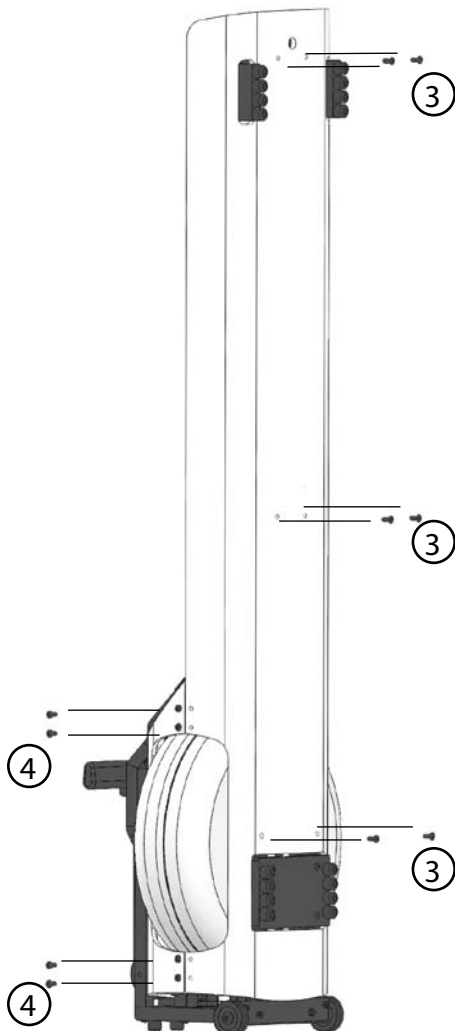

Now screw the wooden hull to the frame (Pos. 3)  
Allen key M8 x 30

Make sure that the bracket on the wooden top are on the inside.

Then screw the wooden hull to the upper part (Pos. 4) with  
8 screws and nuts M8 x 20  
There should be an even spacing between the two shells.

When assembling the front unit, place the rowing machine  
on the floor.

Please only tighten the screws slightly so that they do not  
press into the wood.



Use the washer to control the gap.

### Step 6

Slide the seat onto the rails. The dent on the upholstery points to the rear.

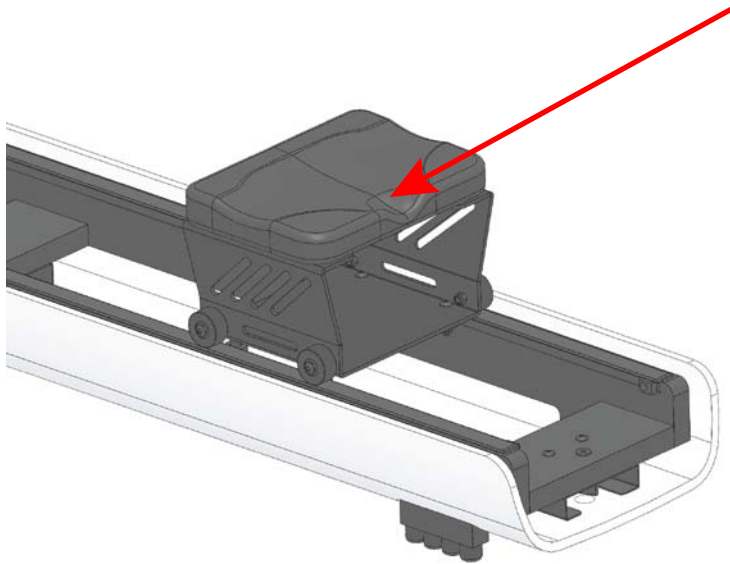

### Step 7

Mount the stopper on both sides. The slanted side faces forward.

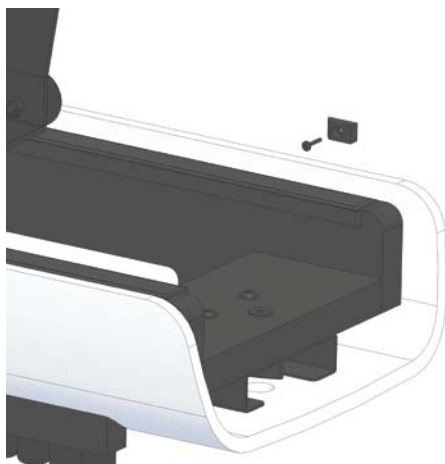

## Filling the water tank

Equipment: Pump and bucket

Fill approx. 13 - 19 liters of clear water into the tank. The amount of water in the tank affects the train resistance.

There is a scale on the side of the tank. Please take care to not exceed the maximum value.

Place the bucket of water on the tank unit. Insert the long flexible hose into the opening of the tank. Place the fixed tube in the bucket. Now do 3-4 pumping movements and the water will flow into the tank. Then close the tank with the plug.



## Training computer

The FLOW ONE training computer is equipped with a 4.3 "TFT color display with touchscreen. The display turns on when you touch the front. After completing the training, the computer switches off automatically after 60 seconds.

Languages: German and English.

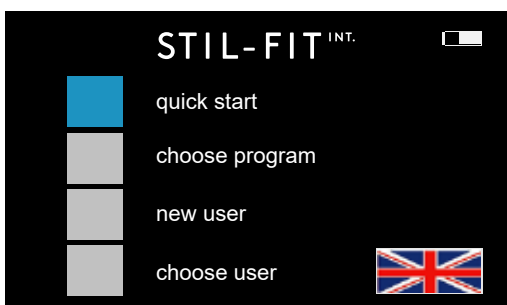

## Start Screen

You can do a quick start, choose a program, select a user or create a user.

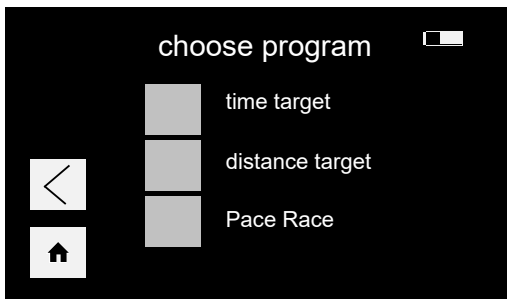

## Trainings programs

- Set time
- Set distance.
- Pace Race mode. Row against a virtual opponent in 9 difficulty levels.

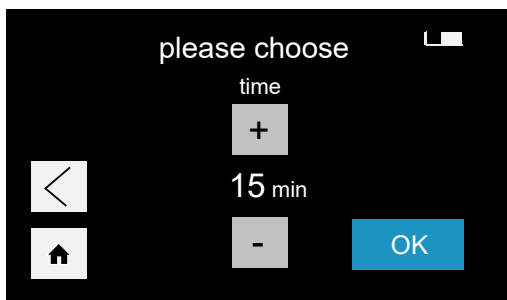

## Setting screen

Depending on the program, the training time or the training route can be set.

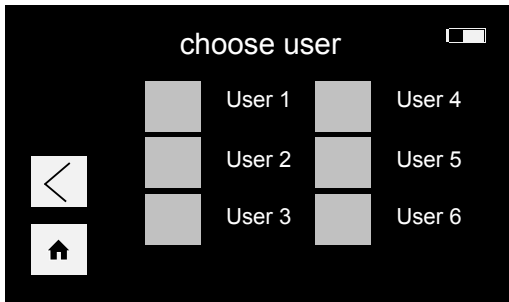

### Create user

You can create up to 6 users.

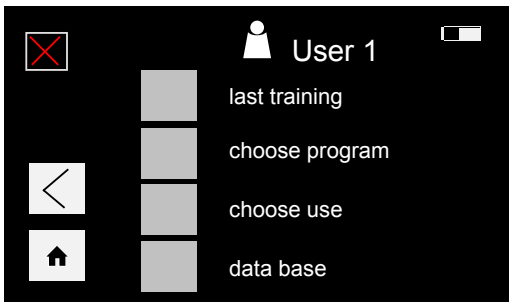

### Account

When you are logged in you can immediately restart the last training session or choose a new program.

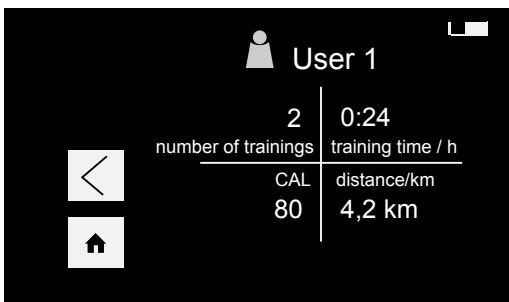

### Database

The number of training sessions, the overall training time, the calories and the distance are stored in the database.

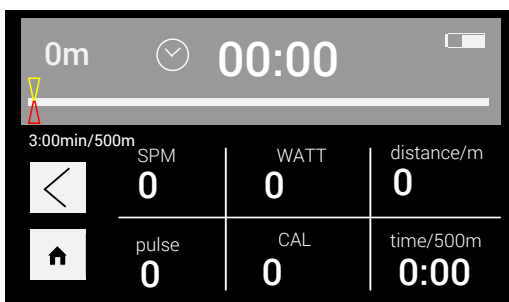
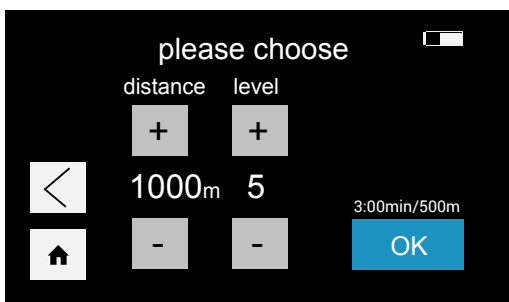

### Pace race

In the Pace Race mode, you can row against a virtual opponent. There are 9 difficulty levels available.

From Level 1: 4: 00min / 500m to Level 9 : 2: 00min / 500m



## Trainings Screen

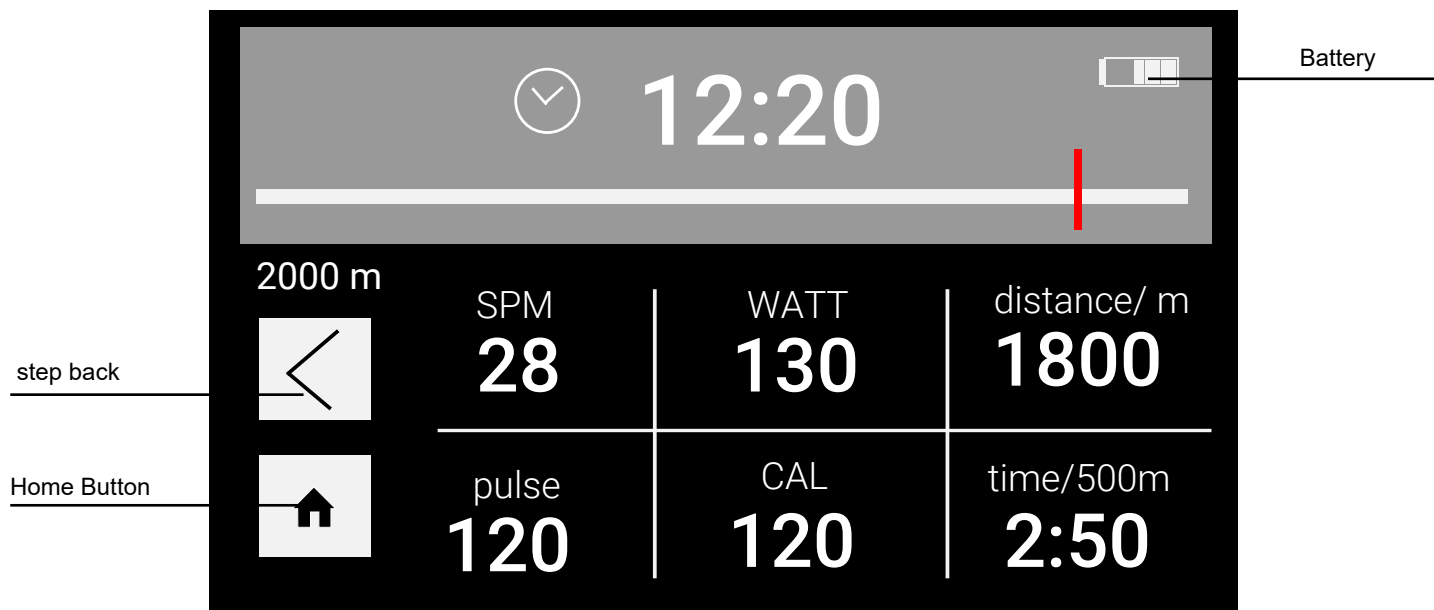

### The following data are displayed:

Training time: With time preselection

Time 500 / m: Time per 500 meters.

SPM: Spins per minute.

Watt: Shows the current wattage.

Distance: The distance is displayed in meters.

Pulse: The pulse is transmitted via a chest strap using Bluetooth smart or Verity Sense from Polar.

Calories: The number of calories consumed.

### Power supply

Power is supplied by an accu which is placed behind the display.

The current charge status is shown on the display.

The accu can be charged by a USB charger Micro 5.0V/DC

The socket is located on the right side of the front metal frame.



Socket

### Maintenance

From time to time clean the rails and the rollers of the seat.

The water does not have to be changed. Put a chlorine tablet in the tank every 3-6 months, then the water remains clear.

## Warranty

STIL-FIT International GmbH grants a 2-year warranty on the FLOW ONE rowing machine for home use.

If a defect occurs in your rowing machine, please contact us or your dealer directly. We will have the device repaired at your home by our service partner in Germany. Other contractual partners are at your side abroad

Mail: [info@stil-fit.com](mailto:info@stil-fit.com)

Phone: +49.89.13 93 60 40

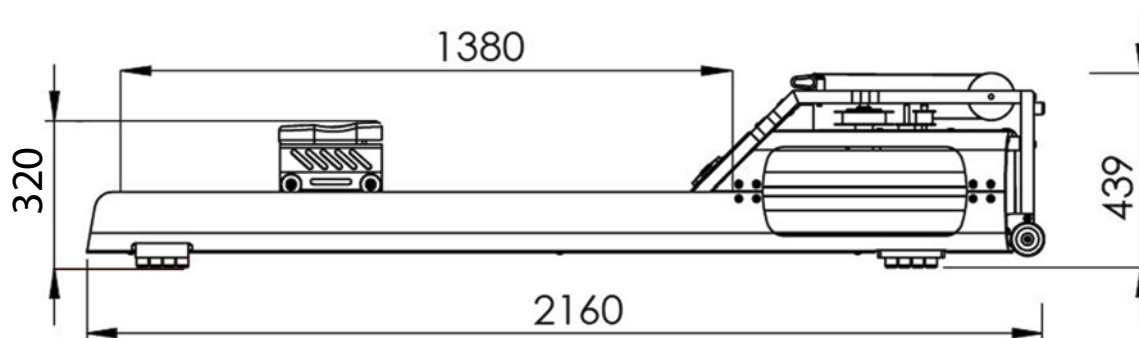

STIL-FIT International GmbH  
Friedenstrasse 18a  
81671 München  
Germany

Tel: +49.89.13 93 60 40

Fax: +49.89.13 93 60 43

[info@stil-fit.com](mailto:info@stil-fit.com)

[www.stil-fit.com](http://www.stil-fit.com)